

352A Direct Roving is specifically designed for CFRT application in PA, PBT, PET, TPU and ABS resins. 352A is designed for Continuous Fiber Reinforced Thermoplastic process and widely used in automotive, construction, transportation and aeronautics applications.

### Product Features

- ⊙ No fuzz
- ⊙ Compatibility with a multiple of resin systems
- ⊙ Good processing
- ⊙ Excellent dispersion
- ⊙ Excellent mechanical properties

### Identification

Glass Type	E			
Type of Size	Silane			
Size Code	352A			
Linear Density, tex	300	600	1200	2400
Filament Diameter, um	13	14	17	17



### Technical Parameters

Linear Density (%)	Moisture Content (%)	Size Content (%)	Breakage Strength (N/tex)
ISO 1889	ISO 3344	ISO 1887	ISO 3341
±5	≤ 0.10	0.50 ± 0.10	≥ 0.35

### Packaging

\* The product can be packed on pallet or in small cardboard boxes.

Package height mm (in)	260 (10)	260 (10)
Package inside diameter mm (in)	160 (6.3)	160 (6.3)
Package outside diameter mm (in)	270 (10.6)	310 (12.2)
Package weight kg (lb)	15.6 (34.4)	22 (48.5)

### Storage

Unless otherwise specified, the fiberglass products should be stored in a dry, cool and moisture-proof area. The room temperature and humidity should be always maintained at 15°C~35°C and 35% ~ 65%. It is best if the product is used within 12 months after production date. The fiberglass products should remain in their original packaging until just prior to user.

To ensure safety and avoid damage to the product, the pallets should not be stacked more than three layers high. When the pallets are stacked in 2 or 3 layers, special care should be taken to correctly and smoothly move the top pallet.

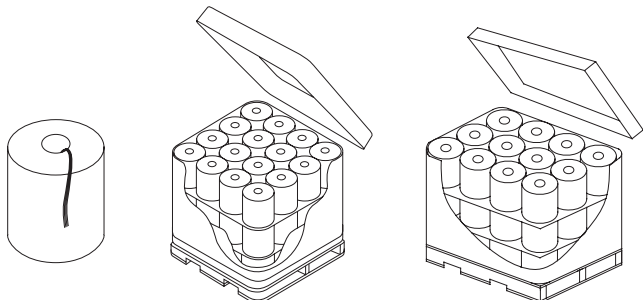

Number of layers	3	4	3	4
Number of doffs per layer	16		12	
Number of doffs per pallet	48	64	36	48
Net weight per pallet kg (lb)	750 (1653.4)	1000 (2204.6)	792 (1746)	1056 (2328)

Pallet length mm (in)	1120 (44)		1270 (50)	
Pallet width mm (in)	1120 (44)		960 (37.8)	
Pallet height mm (in)	940 (37)	1180 (46.5)	940 (37)	1180 (46.5)